

TB 9-4931-393-35

CHANGE 1

DEPARTMENT OF THE ARMY TECHNICAL BULLETIN

CALIBRATION PROCEDURE FOR CALIBRATOR AN/USM-317 (SG-836/USM-317) (HEWLETT-PACKARD MODEL 8402B)

Headquarters, Department of the Army, Washington, DC
13 June 2001

Approved for public release; distribution is unlimited.

TB 9-4931-393-35, dated 5 June 1979 is changed as follows:

1. Remove old pages and insert new pages as indicated below. New or changed material is indicated by a vertical bar in the margin of the page.

Remove pages

1 and 2
5 and 6

Insert pages

1 and 2
5 and 6

2. File this change sheet in front of the publication for reference purposes.

By Order of the Secretary of the Army:

ERIC K. SHINSEKI
General, United States Army
Chief of Staff

OFFICIAL:

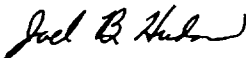
JOEL B. HUDSON
*Administrative Assistant to the
Secretary of the Army*

0116210

Distribution:

To be distributed in accordance with IDN 342843, requirements for calibration procedure TB 9-4931-393-35.

***TB 9-4931-393-35**

DEPARTMENT OF THE ARMY TECHNICAL BULLETIN

CALIBRATION PROCEDURE FOR CALIBRATOR AN/USM-317 (SG-836/USM-317) (HEWLETT-PACKARD MODEL 8402B)

Headquarters, Department of the Army, Washington, DC
5 June 1979

REPORTING OF ERRORS

You can help improve this publication. If you find any mistakes or if you know of a way to improve the procedure, please let us know. Mail your letter or DA Form 2028 to: Commander, U. S. Army Aviation and Missile Command, ATTN: AMSAM-MMC-MA-NP, Redstone Arsenal, AL 35898-5230. A reply will be furnished to you. You may also send in your comments electronically to our e-mail address: 2028@redstone.army.mil or FAX 256-842-6546/DSN 788-6546.

		Paragraph	Page
SECTION	I.	IDENTIFICATION AND DESCRIPTION	
		Test instrument identification.....	1 2
		Calibration data card, DA Form 2416.....	2 2
		Calibration description.....	2 2
	II.	EQUIPMENT REQUIREMENTS	
		Equipment required.....	4 3
		Accessories required.....	5 3
	III.	CALIBRATION PROCESS	
		Preliminary instructions.....	6 4
		Equipment Setup.....	7 4
		Output and stability.....	8 5
		Thermistor resistance.....	9 6
		Power supply.....	10 8
		Final procedure.....	11 9

CHANGE 1

*This bulletin supersedes TB 9-4931-393-35. 15 February 1973.

**SECTION I
IDENTIFICATION AND DESCRIPTION**

1. Test Instrument Identification. This bulletin provides instructions for the calibration of Calibrator, AN/USM-317 (SG-836/USM-317) (Hewlett-Packard Model 8402B). The manufacturer’s instruction manual was used as the prime data source in compiling these instructions. The equipment being calibrated will be referred to as the TI (test instrument) throughout this bulletin.

a. Model variations. TI’s with serial numbers prefixed 610 or 613 use transistors A1Q4 and A1Q5. TI’s prefixed 739 or 811A replace A/94 and A1Q5 with A1Q8 (A-B).

b. Time and technique. The time required for this calibration is approximately 4 hours, using the dc (direct current) and low frequency technique.

2. Calibration Data Card, DA Form 2416

a. Forms, records, and reports required for calibration personnel at all levels are prescribed by TM 38-750. DA Form 2416 must be annotated in accordance with TM 38-750 for each calibration performed.

b. Adjustments to be reported on DA Form 2416 are designated (R) at the end of the sentence in which they appear. When adjustments are in tables, the (R) follows the designated adjustment. Report only those adjustments made and designated with (R).

3. Calibration Description. TI parameters and performance specifications which pertain to this calibration are listed in table 1.

Table 1. Calibration Description

Test instrument parameters	Performance specifications
Line voltage regulation ¹	Satisfactory performance with any line voltage between 103.5 and 126.5 V ac
Calibration points Range Accuracy	0.01 to 2.0 mW ±0.05%
Thermistor operating resistance Range Accuracy	99.5 to 100.5 or 199 to 201Ω ±0.06%

¹Verified from 105 to 125 V ac (volts alternating current).

**SECTION II
EQUIPMENT REQUIREMENTS**

4. Equipment Required. Table 2 identifies the specific equipment used in this calibration procedure. This equipment is issued with Secondary Transfer Standards Calibration Sets NSN 6695-00-621-7877, NSN 6695-00-525-8175 (AN/GSM-256), NSN 493101-019-1829 (AN/GSM-259), and Transportable Maintenance Calibration Facility AN/TSM-55(), and is to be used in performing this procedure. Alternate items may be used by the calibrating activity when the equipment listed in table 2 is not available. The items selected must be verified to perform satisfactorily prior to use and must bear evidence of current calibration. The equipment must meet or exceed the minimum use specifications listed in table 2. The accuracies listed in table 2 provide a four-to-one ratio between the standard and TI.

5. Accessories Required. The accessories listed in table 3 are issued as indicated in paragraph 4 above and are to be used in this calibration procedure. When necessary, these items may be substituted by equivalent items unless specifically prohibited.

Table 2. Minimum Specifications of Equipment Required

Item	Common name and/or official nomenclature	Minimum use specifications	Level A	AN/GSM -256	AN/GSM-259	AN/TSM-55
A1	AUTOTRANSFORMER (VARIABLE POWER TRANSFORMER)	Range: 105 to 125 V ac Accuracy: ±1%	General Radio, Model W10MT3AS3 (7910809)	Same as Level A	Same as Level A	TF-510/U General Radio, Model W10MT3A (6120-054-7794)
A2	DC VOLTMETER (DIFFERENTIAL VOLTMETER)	Range: 0.44699 to 30.05 V dc Accuracy: ±0.0125%	John Fluke, Model 887ABAN (887ABAN)	Same as Level A	Same as Level A	TS-2843 /U John Fluke, Model 883AB (6625-054-6496)
A3	RESISTANCE BRIDGE	Range: 99.44 to 200.12 Ω Accuracy: ±0.015%	ESI, Model 230B (7912150-2) ESI, Model 801 MOD (7912151-2)	ESI, Model 250DER (250DER)	Same as AN/GSM-256	AN/USM-263 (6625-927-4451)

Table 3. Accessories Required

Item	Common name and/or (official nomenclature)	Description and part number
B1	CABLE ASSEMBLY	30-in., RF with double banana plug terminations (Red) (7907470)
B2	LEAD	4-in., No. 18 AWG banana plug terminations (Black) (7907492)
B3	TEST HOOK PROBE ¹	Banana plug to mini-hook (SKC4850-14)

¹Two required.

**SECTION III
CALIBRATION PROCESS**

6. Preliminary Instructions

a. The instructions outlined in paragraphs **6** and **7** are preparatory to the calibration process. Personnel should become familiar with the entire bulletin before beginning the calibration.

b. Items of equipment used in this procedure are referenced within the text by common name and item identification number as listed in tables 2 and 3. For the identification of equipment referenced by item numbers prefixed with A, see table 2, and for prefix B, see table 3.

WARNING

HIGH VOLTAGE is used during the performance of this calibration. DEATH ON CONTACT may result if personnel fail to observe safety precautions.

NOTE

Unless otherwise specified, verify the results of each test and, whenever the test requirement is not met, take corrective action before continuing with the calibration. Adjustments required to calibrate the TI are included in this procedure. Additional maintenance information is contained in the manufacturer's manual for this TI.

NOTE

When indications specified in paragraphs **8** and **9** are not within tolerance, perform the power supply check prior to making adjustments. After adjustments are made, repeat paragraphs **8** and **9**. Do not perform power supply check if all other parameters are within tolerance.

NOTE

Unless otherwise specified, all controls and control settings refer to the TI.

7. Equipment Setup

- a.** Set TI 115-230 V switch (rear panel) to 115 V.
- b.** Remove TI covers as required for access to connections and adjustments.
- c.** Connect TI to autotransformer (A1).
- d.** Connect autotransformer to 115-Vac source and adjust autotransformer for 115 V output.

e. Short POWER METER terminals (rear panel) using lead (B2). Leave short in place throughout calibration.

f. Set MOUNT RESISTANCE switch to 100Ω and FUNCTION switch to calibrate. Allow 30 minutes for equipment to warm up and stabilize.

8. Output and Stability

a. Performance Check

(1) Connect dc voltmeter (A2) to DIFFERENTIAL VOLTMETER terminals on rear panel of TI, using cable assembly (B1).

(2) Set RANGE (MW) switch to .01.

(3) If dc voltmeter does not indicate between 632.14 and 632.78 mV (millivolts), perform **b** below. Record indication.

(4) While observing dc voltmeter indication, vary autotransformer from 105 to 125 V and return to 115 V. The dc voltmeter indication will remain within limits specified in 3 above.

(5) Repeat technique of (2) and (3) above using settings, indications and adjustments listed in table 4.

Table 4. Range Switch

Test instrument RANGE (MW) switch positions	Dc voltmeter indication (V dc)		Adjustments (fig. 1 or 2)	Adjustment dc voltmeter indications (V dc)
	Min	Max		
.03	1.09485	1.09595	A1 R29 (R)	1.09540
.1	1.99900	2.00100	A1 R32 (R)	2.00000
.3	3.46246	3.46594	A1 R33 (R)	3.46420
1	0.632143	0.632777	A1 R36 (R)	0.632460
3	1.09489	1.09599	A1 R37 (R)	1.09544
10	1.99900	2.00100	A1 R40 (R)	2.00000
8	1.78796	1.78976	A1 R43 (R)	1.78886
6	1.54842	1.54998	A1 R46 (R)	1.54920
4	1.26428	1.26556	A1 R48 (R)	1.26492
2	0.893972	0.894868	A1 R51 (R)	0.894420
.01 ¹	0.446986	0.447434	---	---
10 ¹	1.41349	1.41491	---	---

¹Set MOUNT RESISTANCE switch to 200 Ω. These two checks are for low and high ends of RANGE switch for 200 Ω position of MOUNT RESISTANCE switch. If these checks are not within tolerance, it will be necessary to perform power supply adjustments in paragraph 10 and repeat paragraph 8. Due to the interaction of A1R17 and A1R19 with RANGE switch adjustments, it may be necessary to readjust these several times to obtain best indication in all positions.

TB 9-4931-393-35

b. Adjustments. Adjust A1R28 (fig . 1 or 2) to obtain an indication of 632.46 mV on dc voltmeter (R).

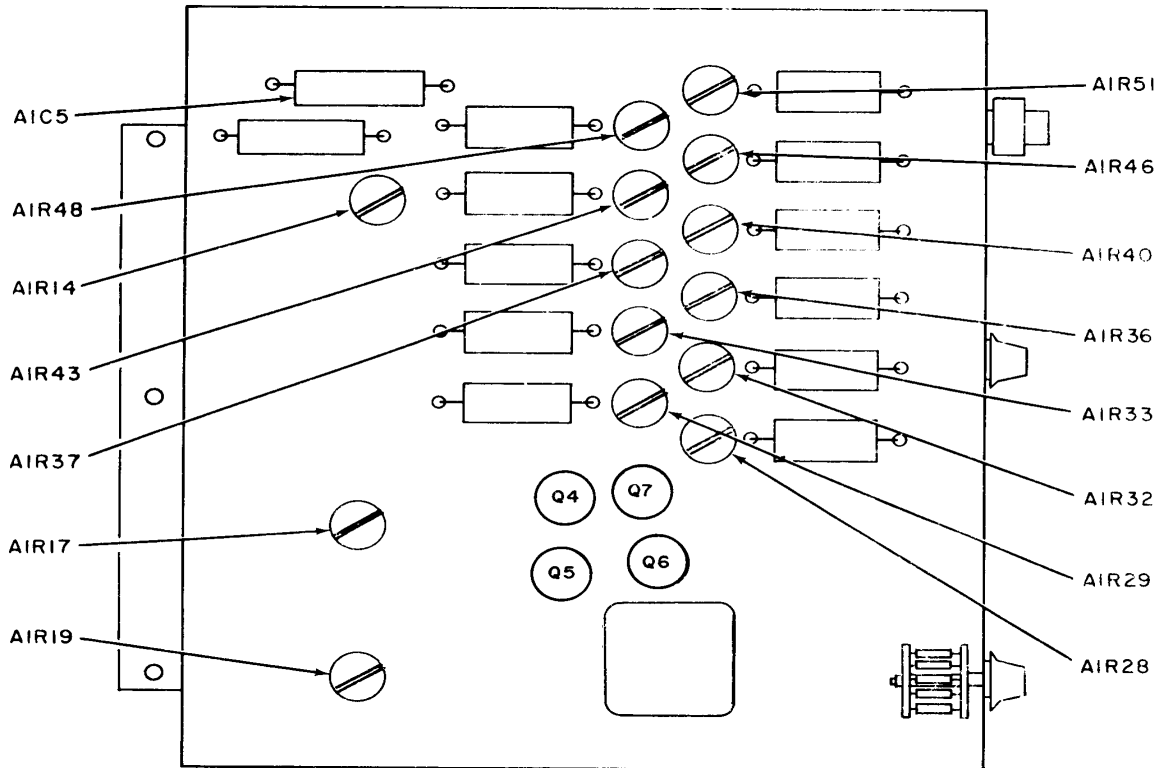

Figure 1. Calibrator assembly board A1-top view. (S/N prefixed 610 or 613).

9. Thermistor Resistance

a. Performance Check

(1) Set Function switch to LINE OFF.

(2) Disconnect TI from autotransformer (A1).

(3) Set MOUNT RESISTANCE switch to 100 Ω and THERMISTOR RESISTANCE (PERCENT) switch to -.5.

(4) Connect resistance bridge (A3) between pins 1 and 2 of TI RESISTANCE STANDARD connector, using Kelvin clip leads furnished with resistance bridge.

(5) Measure resistance. Resistance bridge will indicate between 99.44 and 99.56 ohms.

(6) Repeat technique of (5) above, using settings and indications listed in table 5.

6 CHANGE 1

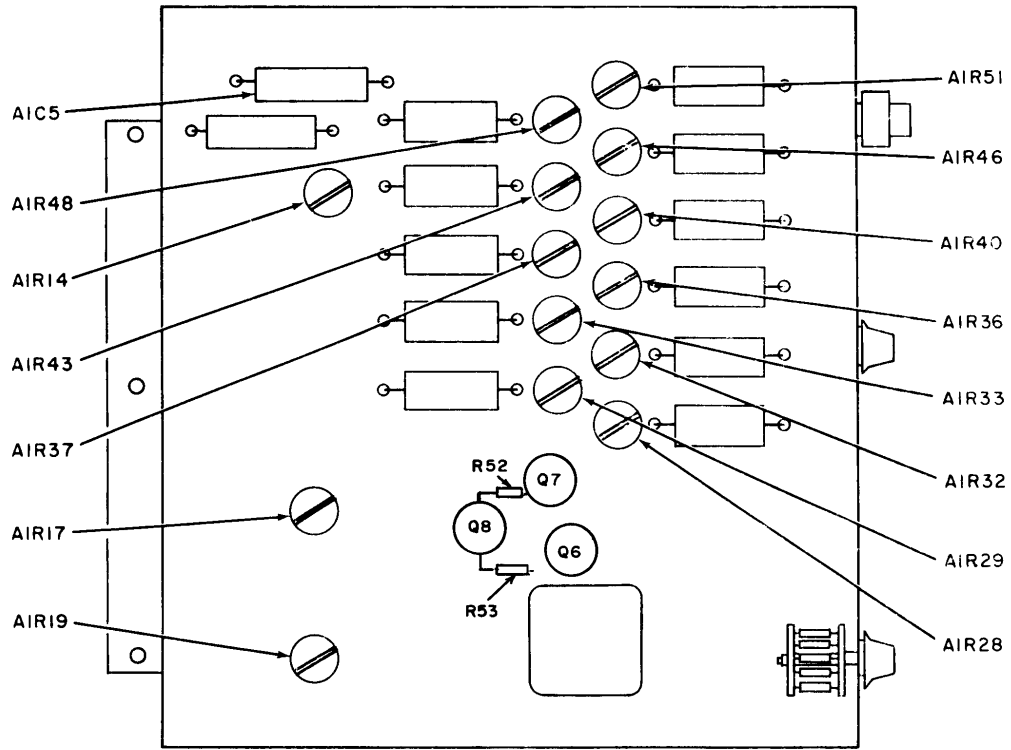

Figure 2. Calibrator assembly board A1-top view (S/N prefixed 739 or 811A).

Table 5. Thermistor Resistance

Test instrument THERMISTOR RESISTANCE (PERCENT) switch settings	Resistance bridge indications (ohms)	
	Min	Max
-4	99.54	99.66
-3	99.64	99.76
-2	99.74	99.86
-1	99.84	99.96
0	99.94	100.06
+1	100.04	100.16
+2	100.14	100.26
+3	100.24	100.36
+4	100.34	100.46
+5	100.44	100.56
0 ¹	199.88	200.12

¹Set MOUNT RESISTANCE switch to 200 Ω.

b. Adjustments. No adjustments can be made.

TB 9-4931-393-35

10. Power Supply

a. Performance Check

NOTE

Do not perform power supply check if all other parameters are within tolerance.

(1) Set FUNCTION switch to CURRENT OFF.

(2) Connect dc voltmeter (A2) across capacitor A1C5 (fig. 1 or 2), using two test hook probes (B3). If dc voltmeter does not indicate between -29.95 and -30.05 Vdc, perform **b(1)** below.

(3) For TIs with serial numbers prefixed 610 or 613, connect dc voltmeter between negative side of A1C5 (fig. 1) and base of A1Q5 (fig. 1), using two test hook probes. For TIs with serial numbers prefixed 739 or 811A, connect dc voltmeter between negative side of A1C5 (fig. 2) and base of A1Q8 (B) which is at junction with R53 (fig. 2). If dc voltmeter does not indicate between +17.748 and 17.752 Vdc, perform **b(2)** below.

NOTE

Float dc voltmeter. The negative side of A1C5 is at -30 Vdc.

(4) Set MOUNT RESISTANCE switch to 200 Ω . If dc voltmeter does not indicate between +12.5495 and +12.5525 Vdc, perform **b(3)** below.

b. Adjustments

(1) Adjust A1R14 (fig. 1 or 2) to obtain dc voltmeter indication of -30.00 Vdc (R).

(2) Adjust A1R17 (fig. 1 or 2) to obtain indication of +17.750 Vdc on dc voltmeter (R).

(3) Adjust A1R19 (fig. 1 or 2) to obtain indication of +12.551 V dc on dc voltmeter (R).

NOTE

Resolution of potentiometers may not permit exact settings specified in (2) and (3) above. If the voltage is set to the high side within limits for the 100-ohm adjustment, set the voltage to the high side within limits for the 200-ohm adjustment, even if it is possible to obtain a setting closer to the exact setting on the low side.

11. Final Procedure

- a.** Deenergize and disconnect equipment.
- b.** Remove short from POWER METER terminals.
- c.** In accordance with TM 38-750, annotate and affix DA Label 80 Army Calibrated Instrument). When the TI receives limited or special calibration, annotate and affix DA Label 163 (US Army Limited or Special Calibration). When the TI cannot be adjusted within tolerance, annotate and affix DA Form 2417 (US Army Calibration System Rejected Instrument).

TB 9-4931-393-35

By Order of the Secretary of the Army:

BERNARD W. ROGERS
General, United States Army
Chief Of Staff

Official:

J. C. PENNINGTON
Major General, United States Army
The Adjutant General

Distribution:

To be distributed in accordance with DA Form 12-34A, (qty rqr block No. 75), requirements for calibration procedures publications.

US GOVERNMENT PRINTING OFFICE 1979-640-042/1249

PIN NO: 009053-000